



HATSAN
ARMS COMPANY



AT44 & AT44-10 Series PCP Air Rifle

INSTRUCTION MANUAL

PLEASE READ THIS MANUAL BEFORE USING YOUR AIR GUN

Thank you for choosing HATSAN AT44 / AT44-10 PCP air rifle.

Always use caution when operating this rifle. Learn and obey the laws of your state and/or country, and be responsible in your use of this air rifle. **Please read this manual completely before handling or shooting your air gun.** It's the sole responsibility of the user to use this air gun properly and safely.

Your air rifle contains many features which gives greater handling, greater accuracy and enjoyment:

- Dovetail groove receiver for both 11mm and 22mm scope mounts.
- Overall blued finish
- Adjustable rubber butt pad
- Precision rifled steel barrel for accuracy
- Manual & Automatic Safety
- Synthetic stock or thumbhole synthetic stock or wooden stock all with raised montecarlo check piece
- Adjustable rear & front sight with fiber optic. (except on models with built-in noise dampeners)
- 2-stage adjustable trigger for trigger travel and trigger pull force.
- Metal trigger
- Detachable air cylinder tube enabling to use spare air cylinders
- Built-in pressure gauge to monitor the cylinder pressure
- Standard quick-fill nozzle & air cylinder discharging cap
- 10 shot magazine (AT44-10 series only)

Warning!

1. **Each HATSAN AT44 / AT44-10 PCP air rifle contains pressurized air and should only be dismantled by a competent gunsmith. Do not attempt to dismantle the rifle if the rifle is partially or fully charged, except for removal and replacement of the air cylinder. Serious injury and/or damage may result if this instruction is ignored. Never shoot the rifle when the air cylinder is removed or empty. This may damage your rifle. Never attempt to dismantle the air cylinder parts or air gauge when the air cylinder is fully or partially charged. Serious injury and/or damage may result if this instruction is ignored.**
2. **Don't use BB pellets with your rifle and use only factory manufactured waisted high quality pellets.**
3. **HATSAN AT44 / AT44-10 PCP air rifle is designed specifically for use with DRY COMPRESSED AIR. NO OTHER GAS OR GAS COMBINATION MUST BE USED. The rifle may be filled from a diver's bottle, a suitable compressor or by using a hand pump specifically made to fill pre-charged air guns. MAXIMUM SAFE WORKING PRESSURE (SWP) : 200 BAR. RECOMMENDED FILL PRESSURE : 190 BAR**

GENERAL INSTRUCTIONS

AT44 & AT44-10 series may have rear & front sight assembled at factory. If not, you should mount Scopes and other alternate optic sights before use. Scopes and other alternate optic sights can also be mounted on AT44 & AT44-10 having rear & front sight. Before using your new air rifle check if it is fully charged and abide the below basic safety rules:

Basic Safety Rules:

1. Treat every rifle as if it is loaded.
2. Never point the rifle at anyone, or allow anyone to point a rifle at you, even if you know it is not loaded.
3. Always carry the rifle so that the direction of the muzzle is under control, even if you stumble.
4. Always be sure of your target and what lies behind it before firing your rifle.
5. Never leave a loaded rifle unattended.
6. Beware of targets that tend to cause ricochets.
7. It is recommended that eye & ear protection is worn when charging the cylinder and when shooting.

Section I. SPECIFICATIONS

AT44 series

AT44 is a single shot, pre-charged, manual loading, pneumatic air rifle.
It is available in cal .177 (4.5mm), cal.22 (5.5mm) and cal.25 (6.35mm).

Barrel Length	495mm / 19.4"
Overall Length	1000mm / 39.4"
Weight	3.3kg / 7.3lbs
Maximum cylinder fill pressure	200 Bar

Number of shots from full charge:

1. 50 effective shots in cal .177 (4.5mm). Total number of shots till the air cylinder become empty is 90.
 2. 50 effective shots in cal.22 (5.5mm). Total number of shots till the air cylinder become empty is 80.
 3. 50 effective shots in cal.25 (6.35mm). Total number of shots till the air cylinder become empty is 70.
- *Number represents count taken in a range of usable, consistent shots using the air cylinder provided with the rifle.

Maximum Muzzle Velocity:

1070fps (325m/s) in cal .177 (4.5mm)
970fps (295m/s) in cal.22 (5.5mm)
670fps (204m/s) in cal.25 (6.35mm)

*Above maximum muzzle velocity figures are when there is no muzzle velocity/energy restriction is implemented on the rifle and when measured at peak value as the velocity will decrease as the pressure in the air cylinder decreases. These maximum velocity figures may differ from country to country depending on the muzzle velocity/energy restriction laws.

** Above velocity figures may show differences depending on the pellet weight and geometry.

AT44-10 series

AT44-10 is a 10- shot, pre-charged, manual loading, pneumatic air rifle.
It is available in cal .177 (4.5mm) and cal.22 (5.5mm)

Barrel Length	495mm / 19.4"
Overall Length	1000mm / 39.4"
Weight	3.3kg / 7.3lbs
Maximum cylinder fill pressure	200 Bar

Number of shots from full charge:

1. 50 effective shots in cal .177 (4.5mm). Total number of shots till the air cylinder become empty is 90.
 2. 50 effective shots in cal.22 (5.5mm). Total number of shots till the air cylinder become empty is 80.
- *Number represents count taken in a range of usable, consistent shots using the air cylinder provided with the rifle.

Maximum Muzzle Velocity:

1070fps (325m/s) in cal .177 (4.5mm)
970fps (295m/s) in cal.22 (5.5mm)

*Above maximum muzzle velocity figures are when there is no muzzle velocity/energy restriction is implemented on the rifle and when measured at peak value as the velocity will decrease as the pressure in the air cylinder decreases. These maximum velocity figures may differ from country to country depending on the muzzle velocity/energy restriction laws.

** Above velocity figures may show differences depending on the pellet weight and geometry.

Section II. BASIC PARTS OF YOUR GUN



- | | | |
|------------------|-------------------------|-----------------------|
| 1. Butt Pad | 6. Safety Button | 11. Rear Sight |
| 2. Stock | 7. Scope Rail | 12. Barrel |
| 3. Pistol Grip | 8. Cocking Handle | 13. Air Cylinder Tube |
| 4. Trigger | 9. Receiver | 14. Front Sight |
| 5. Trigger Guard | 10. Pellet Loading Slot | 15. Muzzle |

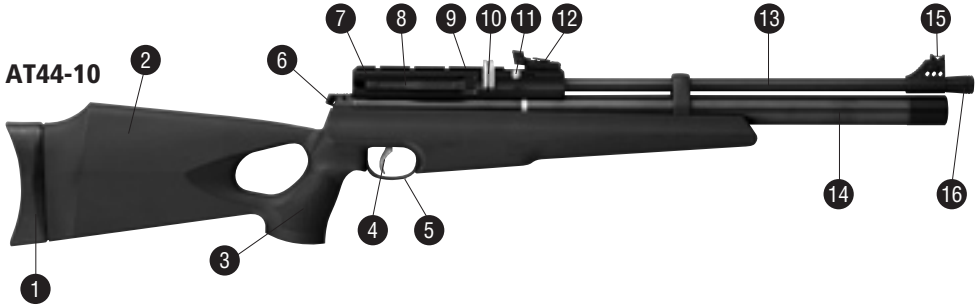

- | | | | |
|----------------|-------------------|---------------------------|-----------------------|
| 1. Butt Pad | 5. Trigger Guard | 9. Receiver | 13. Barrel |
| 2. Stock | 6. Safety Button | 10. 10-Shot Magazine | 14. Air Cylinder Tube |
| 3. Pistol Grip | 7. Scope Rail | 11. Magazine Release Bolt | 15. Front Sight |
| 4. Trigger | 8. Cocking Handle | 12. Rear Sight | 16. Muzzle |

Section III. MANUAL SAFETY

Safety button can be set to 'ON' and 'OFF' position manually.

- To set the safety to "ON", pull safety button. In this position, the trigger cannot be pulled and the gun cannot be shot (Fig. 1).
- To remove the safety to "OFF", push safety button. In this position, the gun is ready to shoot (Fig. 2).

CAUTION: Until you are actually ready to shoot, keep the safety button in the "ON" position (Fig. 1).

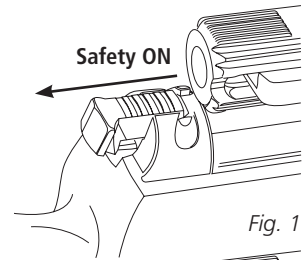

Fig. 1

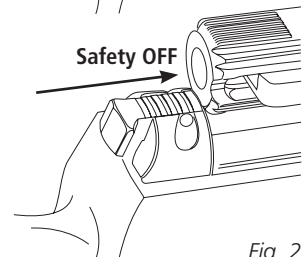

Fig. 2

Section IV. AUTOMATIC SAFETY

This air rifle is equipped with automatic safety. Automatic safety sets the safety to "ON" automatically during cocking of the air rifle by means of the cocking handle. Automatic safety prevents accidental pull of the trigger when the air rifle is cocked, so preventing undesirable charges which may cause damage and/or injury.

Section V. 2-STAGE ADJUSTABLE TRIGGER

This air rifle is equipped with a 2-stage adjustable trigger for trigger travel and trigger pull.

- For less travel of the trigger prior to discharge; turn clockwise the adjustment screw#1. (Fig.3)
- For more travel of the trigger prior to discharge; turn counter-clockwise the adjustment screw#1. (Fig.3)
- For less trigger pull force of the trigger prior to discharge; turn clockwise the adjustment screw#2. (Fig.3)
- For more trigger pull force of the trigger prior to discharge; turn counter-clockwise the adjustment screw#2. (Fig.3)

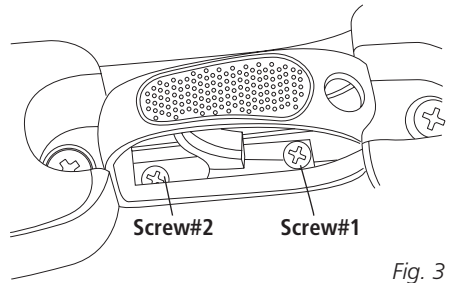

Fig. 3

Section VI. MICRO ADJUSTABLE REAR-SIGHT & ADJUSTABLE FRONT SIGHT

Your air rifle come with fiber optic rear & front sight fitted-except on models with fixed noise-dampener whereas you should fit a scope or other alternate optic sights..

The rear-sight is a sensitive device and can be adjusted both for elevation and windage.

Windage adjustment

- If the shot is deflected to the left of the target, turn the KNOB1 clockwise. (Fig. 4)
- If the shot is deflected to the right of the target, turn the KNOB1 counter-clockwise. (Fig. 4)

Elevation adjustment

- If the shot is too high, turn KNOB2 clockwise. (Fig. 4)
- If the shot is too low, turn KNOB2 screw counter-clockwise. (Fig. 4)

Further elevation adjustment is possible by means of the adjustable front sight.

- If the shot is too high, turn KNOB3 clockwise. (Fig. 5)
- If the shot is too low, turn KNOB3 counter-clockwise. (Fig. 5)

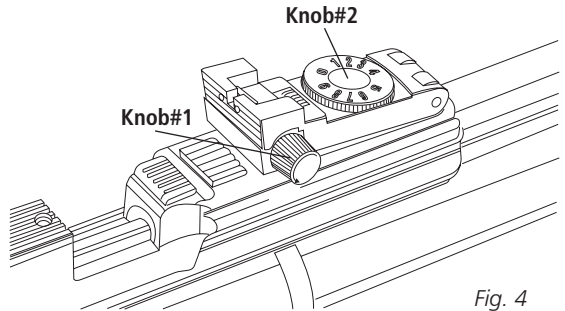

Fig. 4

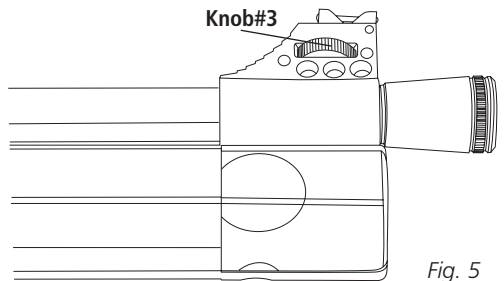

Fig. 5

Section VI. OPERATING INSTRUCTIONS:

Charging the Rifle:

Fit the filler nozzle to the air-line of the charging equipment, which must incorporate a pressure gauge. Ensure both filler nozzle and rifle filler hole are clear from dirt and push the nozzle into the filler hole. Fill the rifle to the cylinder pressure quoted previously in this manual. Do not exceed the maximum fill pressure as this will reduce the velocity of the rifle and may damage rifle components. When using the divers bottle, refill the rifle slowly to prevent the heat created by the filling operation damaging the rifles components.

*Undo the bleeder valve on the hose before disconnecting the fill nozzle from the rifle.

You can assemble spare air cylinder to your rifle. In order to do that, first remove the air cylinder mounted on the rifle by turning it counter-clockwise. Then assemble the spare air cylinder by aligning and rotating it clockwise.

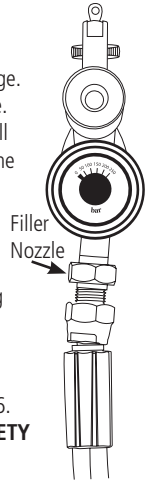

Loading the rifle & shooting in 1-shot version (AT44 series):

1. Pull the cocking lever until it locks and put one pellet into the pellet loading slot as shown in Fig. 6.

THIS OPERATION COCKS THE TRIGGER MECHANISM/HAMMER ASSEMBLY. IF THE SAFETY IS SET TO OFF POSITION AND THE TRIGGER IS PULLED, THE RIFLE WILL DISCHARGE.

2. Close the cocking lever as shown in Fig. 7.

DO NOT CLOSE THE COCKING LEVER UNTIL YOU ARE READY TO SHOOT. ENSURE THE COCKING LEVER IS FULLY CLOSED BEFORE FIRING THE RIFLE AS ITS PERFORMANCE WILL BE AFFECTED IF NOT FULLY CLOSE.

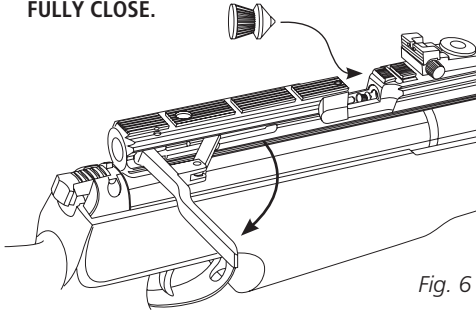

Fig. 6

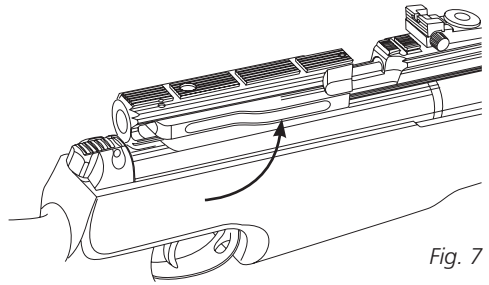

Fig. 7

3. Sight-in either with sights or other optic sights, disengage safety and get ready for shooting.

4. Pull the trigger gently and the rifle will shoot.

5. Repeat above process for the next shots.

Loading the rifle & shooting in 10-shot version (AT44-10 series):

1. The magazine incorporates a raised boss on its rear face and can only be fitted one way to the rifle. It rotates clockwise when viewed from the rear of the rifle. The groove on the side of the barrel housing allows you to observe whether the next magazine chamber about to rotate into alignment with the barrel is loaded with a pellet or empty.

2. To remove the magazine, pull the cocking lever until it locks and push forward the magazine release bolt. Then remove the magazine by pulling it to the right.

(Fig. 6, Fig. 8 & Fig. 9).

THIS OPERATION COCKS THE TRIGGER MECHANISM/HAMMER ASSEMBLY. IF THE SAFETY IS SET TO OFF POSITION AND THE TRIGGER IS PULLED, THE RIFLE WILL DISCHARGE.

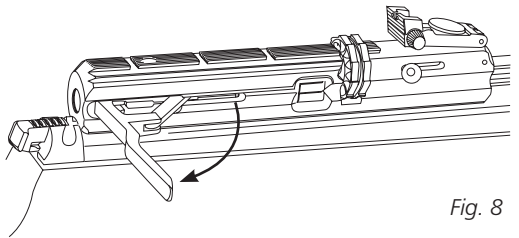

Fig. 8

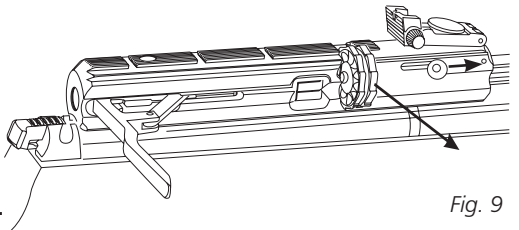

Fig. 9

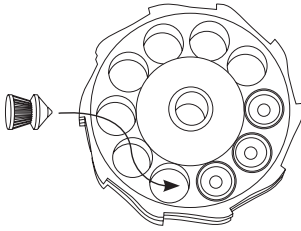

Fig. 10

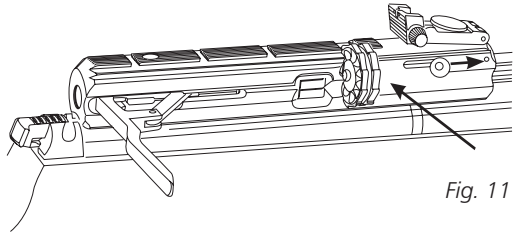

Fig. 11

3. Load pellets through the rear of the magazine. (Fig.10). Push the pellet noses through the retaining O-ring until their skirts lie flush or below the bottom of the magazine face.
4. Push forward the magazine release bolt and assemble back the loaded magazine. Then release the magazine release bolt so that it locks. (Fig.11). If necessary rotate the magazine counter-clockwise until its movement is arrested by the magazine stop.

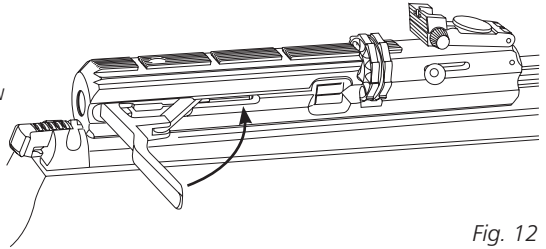

Fig. 12

5. Close cocking lever. (Fig. 12)

DO NOT CLOSE THE COCKING LEVER UNTIL YOU ARE READY TO SHOOT. ENSURE THE COCKING LEVER IS FULLY CLOSED BEFORE FIRING THE RIFLE AS ITS PERFORMANCE WILL BE AFFECTED IF NOT FULLY CLOSE.

6. Sight-in either with sights or other optic sights; disengage safety and get ready for shooting.
7. Pull the trigger gently and the rifle will shoot.
8. To reload rifle, pull the cocking lever fully and close so the next pellet is indexed with the barrel. Then repeat above items 6 & 7.

Note: As the pellets are used and the magazine rotates, its empty chambers become visible above the barrel housing. These chambers may be refilled as they are revealed without removing the magazine if desired.

Note: You cannot cock the rifle and index the next pellet in the magazine unless you shoot the previous pellet in the barrel. This is because of a feature which prevents more than one pellet being loaded in the barrel which may cause damage to the rifle.

Butt Pad Adjustment:

The butt pad is adjustable for height and it rotates slightly over stock providing you the perfect height and angle of the butt pad. In order to adjust the butt pad, simply loosen the bolt in the butt pad with a suitable allen wrench and heighten or lower it according to shooting conformance. Then tighten the bolt.

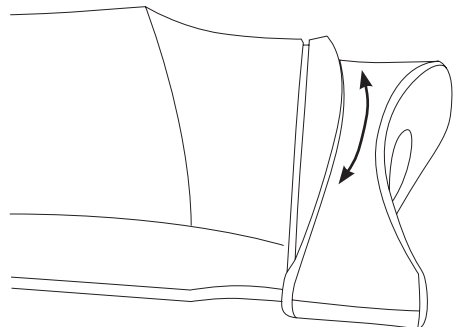
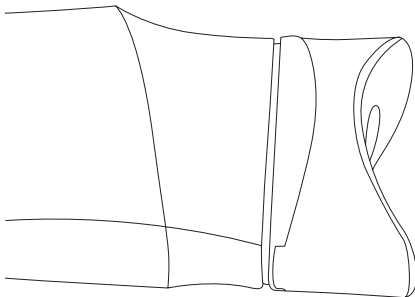

Section VII. MAINTENANCE

WARNING !!

Never attempt to disassemble this rifle when it is charged, except for removal and replacement of the air cylinder. Never fire the rifle when the air cylinder is removed or empty. Failure to obey this instruction could result in damage to your rifle.

Never lubricate inside the barrel as this will affect the accuracy & grouping of the rifle in negative manner.

Occasionally apply proper mineral based oils sparingly to the following parts:

- The trigger mechanism
- The pellet probe
- The cocking lever sliding surface
- The stern of the magazine pin and the magazine release.
- The magazine axis hole and the outer O-ring.

DO NOT OVER-LUBRICATE THE RIFLE!

- It is recommended to clean the barrel with a cleaning rod every 500 shots. Never lubricate inside the barrel.
- Before you begin oiling or cleaning your air gun, always check to make sure it is unloaded.
- Always be sure your gun barrel is clean and not blocked.
- After cleaning ensure that no cleaning patch or other obstruction remains in the barrel.
- Take your air gun to a gunsmith if water, sand, etc. enters the internal mechanism of the air gun, for complete cleaning.
- Dangerous conditions may occur if you do not keep your air gun clean and working properly.

Quick Fill Nozzle O-Rings Replacement

After a period of time, the O-rings on the fill nozzle will need to be replaced. The need for this will become noticeable if air is heard leaking from the nozzle or the nozzle ejected from the rifle while charging the rifle. Always ensure to replace both O-rings.

Magazine O-rings Replacement (on AT44-10 series only)

The O-ring which retains the pellets in the magazine will need to be replaced after many hundreds of shots have been shot. Its replacement becomes apparent when the rifle's cocking lever becomes stiff to operate. Repositioning the O-ring in its groove may also overcome the stiffness. Lightly oil the replacement O-ring before fitting.

Safety Measures & Warnings

- This air gun will shoot if cocked, loaded, safety disengaged and trigger pulled.
- Air guns are not toys. Never let young children use an air gun unsupervised. Adult supervision is strictly required during use. Misuse or careless use may cause serious injury or death.
- Learn how your air gun operates and safe gun handling procedures before loading and using it.
- ALWAYS USE EYE & HEARING PROTECTION AND MAKE BYSTANDERS USE THE SAME. Failure to do so may result in eye injuries and permanent hearing loss.
- Do not point at anything you do not intend to shoot even though the gun is unloaded. Always keep the gun pointed in a safe direction.
- Never pull a gun toward you by the muzzle.
- Always aim at a safe target, taking care that it does not conceal any other object.
- Before you shoot, consider where the pellet will travel should you miss your intended target, thus ensuring no damage or harm could result.
- Be sure of your target before you pull the trigger. Never shoot at sounds.
- When shooting, always have a safe shooting range, that is; have a safe area for shooting, a safe distance between you and the target, and a safe backstop to trap the pellets and hold the target.
- Do not shoot at a target, which allows ricochets or deflections. Do not shoot into or at water.

- Do not shoot at or near power lines or insulators. Be especially careful in wooded areas where power lines may not be as visible.
- Do not load the gun until you are ready to shoot.
- Always keep your fingers away from the trigger & muzzle during cocking and handling.
- Do not walk, run or jump when carrying a loaded or cocked air gun. A loaded or a cocked gun should never be carried inside a vehicle, house, camp or public place. Never climb a tree or fence or jump a ditch with a loaded gun. In such a case, first unload it and hand the gun to a friend or place it on the ground on the other side of the obstacle before crossing yourself.
- When transporting the gun, keep it unloaded and 'on safe'.
- Always keep the gun 'on safe' until you are ready to shoot even if the gun is unloaded.
- Do not put the gun away loaded and unattended.
- Always check to see if the gun is 'on safe' and unloaded when getting it from another person or from storage.
- Always keep the air gun and/or pellets out of the reach of children. Keep the air gun and pellets in separate places, better if under lock and key.
- Do not attempt to disassemble or tamper with your gun. Use a competent gunsmith. Many air guns contain powerful springs or high pressure air cylinders which can cause serious injury if released in an uncontrolled manner.
- Always handle and treat your gun as though it were loaded.
- Improper use or handling of air guns is not the responsibility of the manufacturer or distributor, under any circumstances. The user is responsible for any harm, which may be caused.
- Think first, shoot second. Don't rely on any mechanical safety. Half safe is not safe.
- Be safe not sorry. Respect other's property.
- Air guns should never be used under the influences of alcohol or drugs.



HATSAN

ARMS COMPANY

Izmir - Ankara Karayolu 28. km. No. 289
35170, Kemalpaşa İzmir - TURKEY
Tel: +90 (232) 878 91 00 • Fax: +90 (232) 878 91 02
www.hatsan.com.tr info@hatsan.com.tr